

Nexans LANactive FTTO Switches

User Manual

Version 2.1, November 2021



88303910	GigaSwitch V5 TP(PSE+) SFP-2VI 54VDC
88303920	GigaSwitch V5 TP SFP-2VI 54VDC
88303990	GigaSwitch V5 2TP(PSE+) SFP-VI 54VDC
88303991	GigaSwitch V5 2TP(PD-F+) SFP-VI 54VDC
88303992	GigaSwitch V5 2TP SFP-VI 54VDC
88303971	GigaSwitch V5 SFP-2VI 230VAC
88303975	GigaSwitch V5 TP SFP-VI 230VAC

FOREWORD

Nexans Advanced Networking Solutions offers over 35 years of experience in research, development and production of Fibre To The Office (FTTO) switches, Industrial Ethernet switches and network design. All key components are designed and manufactured by Nexans in Germany to offer highest product quality and lifetime.

Nexans "Made in Germany" IT-networking solutions have proven their reliability in countless projects with over 1 million user ports installed. As a market pioneer for Fibre To The Office Systems, Nexans has a strong R&D heritage based on the principal of close customer centric product development and supports customers through all stages of even the most complex projects with a dedicated support department.

Nexans Advanced Networking Solutions GmbH is part of Nexans headquartered in Paris and listed on Euronext Paris, Compartment A with a main footprint on the European market.

A scalable and flexible IT infrastructure forms the basis for smooth operation and guarantees high-performance network performance for today's and tomorrow's applications.

Fibre is the best medium because of its scalability. The Fibre to the Office (FTTO) concept combines the benefits of fibre with the flexibility, cost-effectiveness, and interoperability requirements of today's enterprise networks.

Purpose of this user manual

This manual describes the features, functions, operation and initial operation of the GigaSwitch V5 series. It may include more than one product. Part of the content, e.g. some use cases or specifications, may only apply to some of them. For more information on the exact feature set and specifications, see the product's web page and datasheet.

Target group

Planners and installers of FTTO solutions, electrical engineers, persons entrusted with setting, testing and maintaining FTTO switches.

Support

If you are not yet a registered user of Nexans Support Portal, please register at the Nexans support portal <https://www.nexans-ans.de/support/> and download the latest version of the firmware and the management tool. In the Support Portal you will also find the related V5 release notes and the current versions of V5 management manual.

If you have any questions or problems, please contact us at the following support e-mail address: support.ans@nexans.com.

In order to benefit from individualized and extended product support, we recommend concluding a Nexans support contract. If you are interested, please send us your request by e-mail to sales.ans@nexans.com.

Disclaimer

The content of this manual has been checked for compliance with the hardware and software described. Nevertheless, deviations cannot be ruled out, so no liability is assumed for the complete agreement. The information in this manual is reviewed regularly and any necessary corrections are included in subsequent editions. Suggestions for improvement are welcomed. Technical changes are reserved, even without notice.

Further information can be found at www.nexans.de/LANsystems

Nexans Advanced Networking Solutions GmbH
Bonnenbroicher Str. 2-14
41238 Moenchengladbach
Germany
Tel: +49 2166 27-2220
E-Mail: sales.ans@nexans.com

TABLE OF CONTENTS

Foreword.....	1
Table of Contents.....	3
EC Declaration of Conformity.....	4
Features and Benefits.....	5
Specifications.....	6
Dimensions.....	11
Interface Description.....	12
Product Labels.....	16
Safety Instructions.....	17
Installation of FTTO switches.....	18
Horizontal and Vertical Installation.....	19
Power Connection.....	21
Grounding.....	23
Hardware Installation.....	24
Installation Distances.....	26
Power over Ethernet.....	27
Memory Cards and Console Cable.....	29
LED Behavior.....	30
Start-up – Booting.....	31
Configuration- and Reset Button.....	32
LANactive Manager.....	34
GigaSwitch Product List.....	35
Accessories.....	37

EC DECLARATION OF CONFORMITY

The manufacturer

Nexans Advanced Networking Solutions GmbH
Bonnenbroicher Strasse 2-14
41238 Moenchengladbach
Germany

declares under its sole responsibility that the products:

- **88303910** **GigaSwitch V5 TP(PSE+) SFP-2VI 54VDC**
- **88303920** **GigaSwitch V5 TP SFP-2VI 54VDC**
- **88303990** **GigaSwitch V5 2TP(PSE+) SFP-VI 54VDC**
- **88303991** **GigaSwitch V5 2TP(PD-F+) SFP-VI 54VDC**
- **88303992** **GigaSwitch V5 2TP SFP-VI 54VDC**
- **88303971** **GigaSwitch V5 SFP-2VI 230VAC**
- **88303975** **GigaSwitch V5 TP SFP-VI 230VAC**

following the provisions of directives

- **2014/30/EU Electromagnetic Compatibility Directive**
- **2014/35/EU Low Voltage Directive**
- **2011/65/EU RoHS 2**

to which this declaration relates are in conformity with the following directives and standards:

- **EN 62368-1:2014:** Audio/video, information and communication technology equipment - Part 1: Safety requirements
- **EN 55032:2012:** Electromagnetic compatibility of multimedia equipment - Emission requirements
- **EN 55024:2016:** Information technology equipment - Immunity characteristics - Limits and methods of measurement
- **EN 61000-3-2:2014:** Electromagnetic compatibility (EMC) - Part 3-2: Limits - Limits for harmonic current emissions
- **EN 61000-3-3:2013:** Electromagnetic compatibility (EMC) - Part 3-3: Limits - Limitation of voltage changes, voltage fluctuations and flicker in public low-voltage supply systems, for equipment with rated current $\leq 16A$ per phase and not subject to conditional connection
- **EN 50581:2012:** Technical documentation for the assessment of electrical and electronic products with respect to the restriction of hazardous substances

The quality and environmental management system of Nexans Advanced Networking Solutions GmbH according to DIN EN ISO 9001:2000 and DIN EN ISO 14001:2005 ensures compliance with the European Directives and the fulfilment of the relevant standards of the European standards bodies CEN, CENELEC and ETSI.

FEATURES AND BENEFITS

LANactive full managed Gigabit Ethernet FTTO Switches

- Four user ports connecting end devices like PC, VoIP Phones or printer
- Up to three uplinks in various combinations
- Power over Ethernet (PoE+) with up to 30W output power
- Memory Card Slot
- Electrical connection for 54V DC or 230CV AC

Description

Nexans LANactive GigaSwitch V5 series is designed for the installation in Fibre to the Office (FTTO) networks. The latest generation of FTTO switches is equipped with a state-of-the-art network processor and provides enhanced performance, security and redundancy functionality.

The LANactive GigaSwitch product portfolio with various port combinations, optionally supporting Power over Ethernet, can be installed and used in different network infrastructures and fulfil the latest network requirements.

Snap-In Installation

The very compact design of LANactive GigaSwitch allows a tool-less snap-in installation into the standard 45 mm cable duct systems or floor boxes without special mounting accessories. FTTO installations can be realized in the shortest possible time in combination with the latest Click-In power supply series.

Power Source Equipment (PSE+)

Depending on the version the LANactive GigaSwitch supports Power over Ethernet (PoE+) functionality. Devices like VoIP-Phones, Wireless-Access-Points and IP-Cameras can be directly supplied with power from the switch according to IEEE802.3at. The Power over Ethernet functionality can be parameterized, controlled and monitored via switch management.

Memory Card

The optional memory card automatically saves the complete current configuration and firmware of the LANactive GigaSwitch. In case of failure, this feature allows an easy exchange of the hardware without additional configuration. In addition, each memory card can be delivered with its own MAC address that is adopted by the switch.

Switch Management and Zero-Touch Configuration

The LANactive Manager allows a simple and secure configuration of all device parameter of the GigaSwitch series. With LANactive Manager a larger number of GigaSwitch systems can be managed and monitored at the same time. In combination with Nexans Zero-Touch Configuration, the LANactive Manager allows an automatic distribution of configurations and firmware updates. A pre-configuration of the switches is not necessary.

Fanless design

The fanless design of the GigaSwitch has many advantages: e.g. energy savings, high MTBF values and noiseless operation allowing an installation in offices and business environments.

Rotatable User Ports

The module with the four user ports, also called head of the switch, is rotatable and can be mounted in a vertical as well as in a horizontal installations.

SPECIFICATIONS

General specifications

Ordering Information	GigaSwitch V5 TP(PSE+) SFP-2VI 54VDC	GigaSwitch V5 TP SFP-2VI 54VDC
Article Number	88303910	88303920
Interfaces		
User Ports (RJ45)	4x 1000Base-T	
Uplink Ports (SFP)	2x 100/1000Mbps	
Uplink Ports (RJ45)	1x 1000Base-T	
RJ45 Ports	Auto-Negotiation, MDI/MDI-X Auto-Cross Over and Auto-Polarity	
Eco Mode for RJ45 Ports	Yes	
Rotatable Head Module	Yes	
Power over Ethernet		
Number of PoE User Ports	4x PoE-PSE acc. to IEEE802.3at	
Number of PoE Uplink Ports	1x PoE-PSE acc. to IEEE802.3at	-
PoE Mode	30W per Port, Mode A, Pin 1-2/3-6	
Max. PoE power budget	150W	120W
Diagnostic Functions (Interfaces)		
Digital Diagnostics Monitoring Interface	Yes	
Twisted Pair Cable Diagnostic	Yes	
General		
Dimensions [W x H x D]	90mm x 45mm x 69mm	
Installation Depth	35mm	
Material	zinc diecasting / stainless steel	
Colour	Pure White, like RAL 9010	
Ambient Temperature	Operation: 0 ... 45°C, Storage: -20 ... 85°C	
Relative Humidity	20 ... 90% (non-condensing)	
Weight	290g	
MTBF	> 750,000h	

Specifications

Contact

Nexans LAN Systems
Tel.: +49 (0) 2166 27 2220
sales.ans@nexans.com

Power Supply

Input Voltage	46 ... 57V DC (typ. 54V DC)
Power Consumption	4.4W typical, 6.2W max.
Heat Output	22Btu(IT)/h
Connector	3-pin connector (up to 2.5mm ²) / (+) (-) (FPE)

CE - Conformity

Electro Magnetic Capability Directive	2014/30/EU
Low Voltage Directive	-
RoHS 2	2011/65/EU
Engineering Standards	EN 62368-1, EN 55032, EN 55024, EN 50581

Specifications

Contact

Nexans LAN Systems
Tel.: +49 (0) 2166 27 2220
sales.ans@nexans.com

Ordering Information	GigaSwitch V5 2TP(PSE+) SFP-VI 54VDC	GigaSwitch V5 2TP(PD-F+) SFP-VI 54VDC	GigaSwitch V5 2TP SFP-VI 54VDC
Article Number	88303990	88303991	88303992
Interfaces			
User Ports (RJ45)		4x 1000Base-T	
Uplink Ports (SFP)		1x 100/1000Mbps	
Uplink Ports (RJ45)		2x 1000Base-T	
RJ45 Ports	Auto-Negotiation, MDI/MDI-X Auto-Cross Over and Auto-Polarity		
Eco Mode for RJ45 Ports		Yes	
Rotatable Head Module		Yes	
Power over Ethernet			
Number of PoE User Ports		4x PoE-PSE acc. to IEEE 802.3at	
Number of PoE Uplink Ports	2x PoE-PSE acc. to IEEE802.at	1x PoE-PD 1x PoE-PSE acc. to IEEE802.at	-
PoE Mode		30W per Port, Mode A, Pin 1-2/3-6	
Max. PoE power budget with ext. PS		150W	120W
Max. PoE power budget as PD	-	19.5W	-
Diagnostic Functions (Interfaces)			
Digital Diagnostics Monitoring Interface		Yes	
Twisted Pair Cable Diagnostic		Yes	
General			
Dimensions [W x H x D]		90mm x 45mm x 69mm	
Installation Depth		35mm	
Material		zinc diecasting / stainless steel	
Colour		Pure White, like RAL 9010	
Ambient Temperature		Operation: 0 ... 45°C, Storage: -20 ... 85°C	
Relative Humidity		20 - 90% (non-condensing)	
Weight		290g	
MTBF		> 750,000h	

Specifications

Contact

Nexans LAN Systems
Tel.: +49 (0) 2166 27 2220
sales.ans@nexans.com

Power Supply

Input Voltage	46 ... 57V DC (typ. 54V DC)	PoE acc. to IEEE802.3at or 46 ... 57V DC (typ. 54V DC)	46 ... 57V DC (typ. 54V DC)
---------------	-----------------------------	--	-----------------------------

Power Consumption	5.3W (typ.) ... 6.2W (fully connected)		
-------------------	--	--	--

Heat Output	22 Btu(IT)/h		
-------------	--------------	--	--

Connector	3-pin connector (up to 2.5mm ²) / (+) (-) (FPE)		
-----------	---	--	--

CE – Conformity

Electro Magnetic Capability Directive	2014/30/EU		
---------------------------------------	------------	--	--

Low Voltage Directive	-		
-----------------------	---	--	--

RoHS 2	2011/65/EU		
--------	------------	--	--

Engineering Standards	EN 62368-1, EN 55032, EN 55024, EN 50581		
-----------------------	--	--	--

Specifications

Contact
Nexans LAN Systems
Tel.: +49 (0) 2166 27 2220
sales.ans@nexans.com

Ordering Information	GigaSwitch V5 TP SFP-VI 230VAC	GigaSwitch V5 SFP-2VI 230VAC
Article Number	88303975	88303971
Interfaces		
User Ports (RJ45)	4x 1000Base-T	
Uplink Ports (SFP)	1x 100/1000Mbps	2x 100/1000Mbps
Uplink Ports (RJ45)	1x 1000Base-T	-
RJ45 Ports	Auto-Negotiation, MDI/MDI-X Auto-Cross Over and Auto-Polarity	
Eco Mode for RJ45 Ports	Yes	
Rotatable Head Module	Yes	
I/O Contacts	1x function input for connecting a dry contact	
Diagnostic Functions (Interfaces)		
Digital Diagnostics Monitoring Interface	Yes	
Twisted Pair Cable Diagnostic	Yes	
General		
Dimensions [W x H x D]	90mm x 45mm x 69mm	
Installation Depth	35mm	
Material	zinc diecasting / stainless steel	
Colour	Pure White, like RAL 9010	
Ambient Temperature	Operation: 0 ... 45°C, Storage: -20 ... 85°C	
Relative Humidity	20 ... 90% (non-condensing)	
Weight	290g	
MTBF	> 750,000h	
Power Supply		
Input Voltage	85 ... 240V AC (typ. 110V or 230V AC)	
Power Consumption	4.5W typical, 5.7W max.	
Heat Output	22Btu(IT)/h	
Connector	3-pin screwable connector (up to 1.5mm ²) / (PE) (L) (N)	
CE – Conformity		
Electro Magnetic Capability Directive	2014/30/EU	
Low Voltage Directive	2014/35/EU	
RoHS 2	2011/65/EU	
Engineering Standards	EN 62368-1, EN 55032, EN 55024, EN 61000-3-2, EN 61000-3-3, EN 50581	

DIMENSIONS

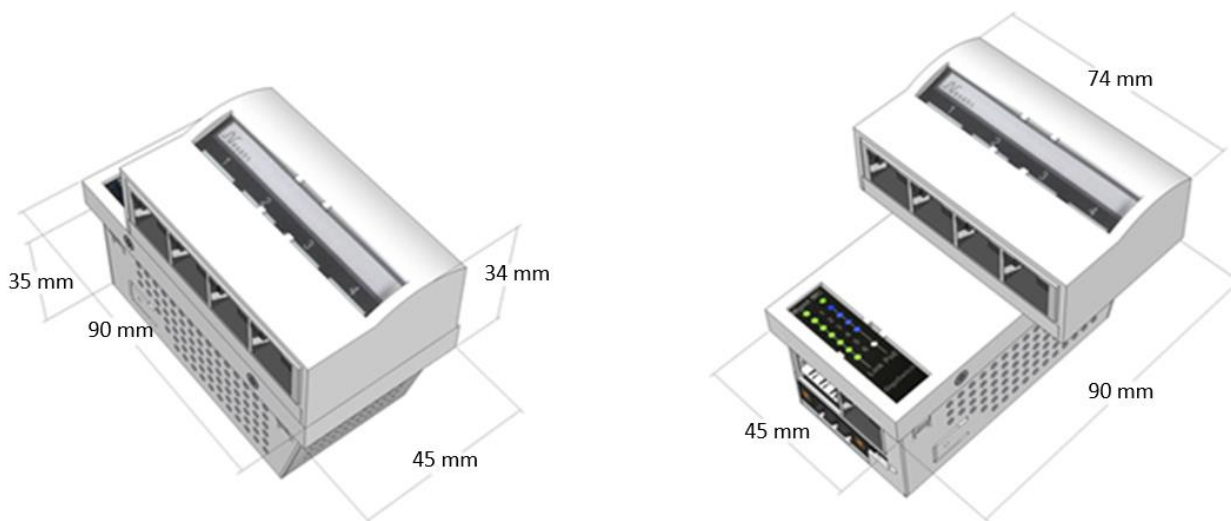

Figure 1: LANactive GigaSwitch dimensions

Interface Description

Contact
 Nexans LAN Systems
 Tel.: +49 (0) 2166 27 2220
 sales.ans@nexans.com

INTERFACE DESCRIPTION

88303910

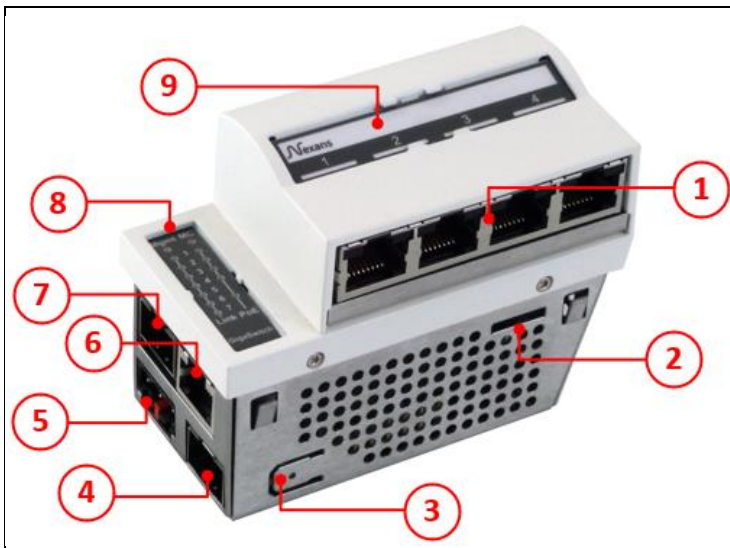

Number	Description
1	Port 1 - 4: RJ45 User Ports (PoE-PSE)
2	Memory card slot (microSD)
3	Grounding terminal
4	Port 7: SFP Uplink
5	3-pin power connection
6	Port 6: RJ45 Uplink (PoE-PSE)
7	Port 5: SFP Uplink
8	Status LEDs
9	Labelling

88303920

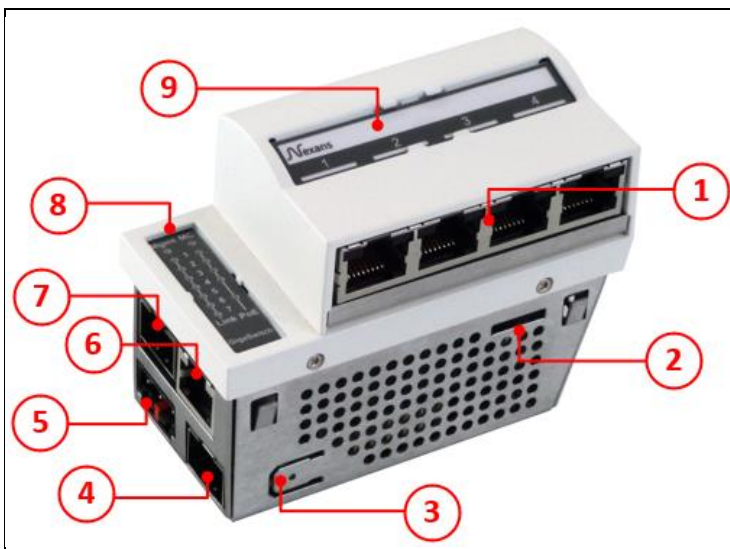

Number	Description
1	Port 1 - 4: RJ45 User Ports (PoE-PSE)
2	Memory card slot (microSD)
3	Grounding terminal
4	Port 7: SFP Uplink
5	3-pin power connection
6	Port 6: RJ45 Uplink
7	Port 5: SFP Uplink
8	Status LEDs
9	Labelling

Interface Description

Contact
 Nexans LAN Systems
 Tel.: +49 (0) 2166 27 2220
 sales.ans@nexans.com

88303990

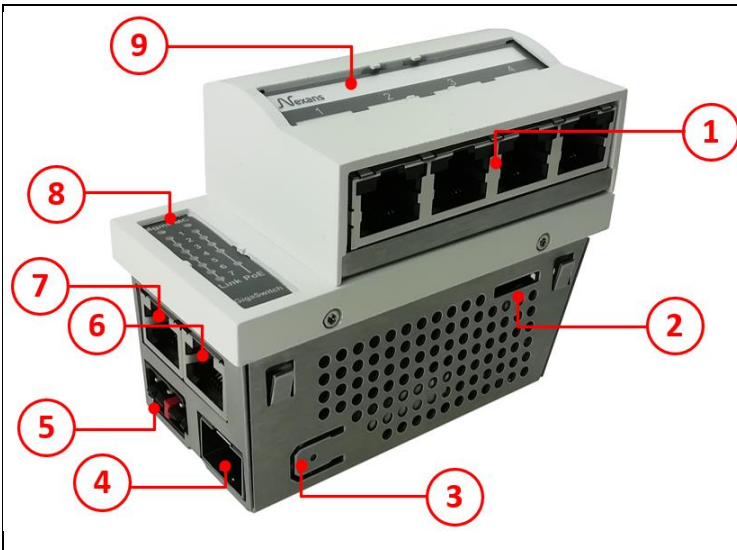

Number	Description
1	Port 1 - 4: RJ45 User Ports (PoE-PSE)
2	Memory card slot (microSD)
3	Grounding terminal
4	Port 7: SFP Uplink
5	3-pin DC power connection
6	Port 6: RJ45 Uplink (PoE-PSE)
7	Port 5: RJ45 Uplink (PoE-PSE)
8	Status LEDs
9	Labelling

88303991

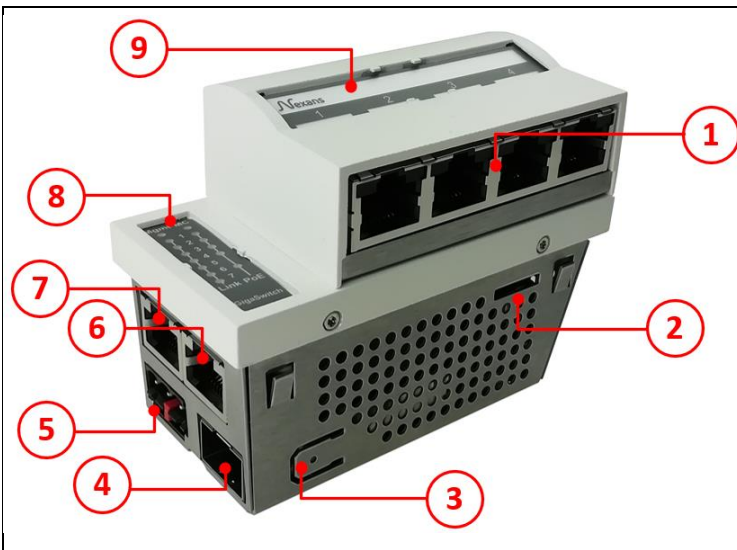

Number	Description
1	Port 1 - 4: RJ45 User Ports (PoE-PSE)
2	Memory card slot (microSD)
3	Grounding terminal
4	Port 7: SFP Uplink
5	3-pin DC power connection
6	Port 6: RJ45 Uplink (PoE-PSE)
7	Port 5: RJ45 Uplink (PoE-PD)
8	Status LEDs
9	Labelling

Interface Description

Contact
Nexans LAN Systems
Tel.: +49 (0) 2166 27 2220
sales.ans@nexans.com

88303992

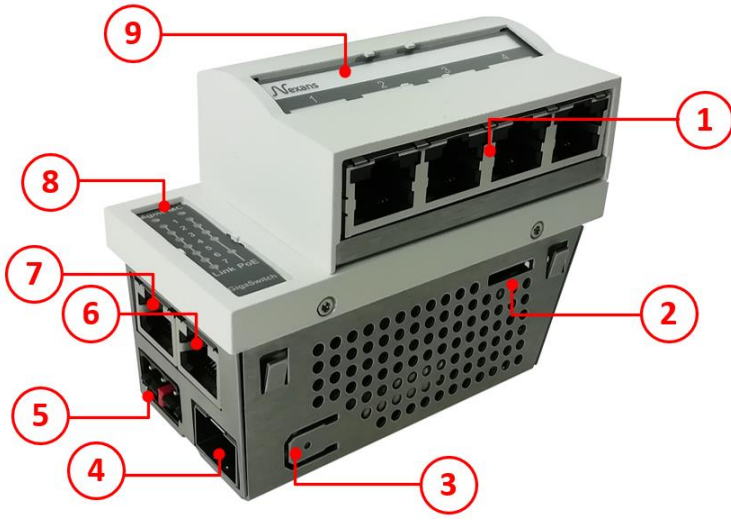

Number	Description
1	Port 1 - 4: RJ45 User Ports (PoE-PSE)
2	Memory card slot (microSD)
3	Grounding terminal
4	Port 7: SFP Uplink
5	3-pin DC power connection
6	Port 6: RJ45 Uplink
7	Port 5: RJ45 Uplink
8	Status LEDs
9	Labelling

Interface Description

Contact
 Nexans LAN Systems
 Tel.: +49 (0) 2166 27 2220
 sales.ans@nexans.com

88303971

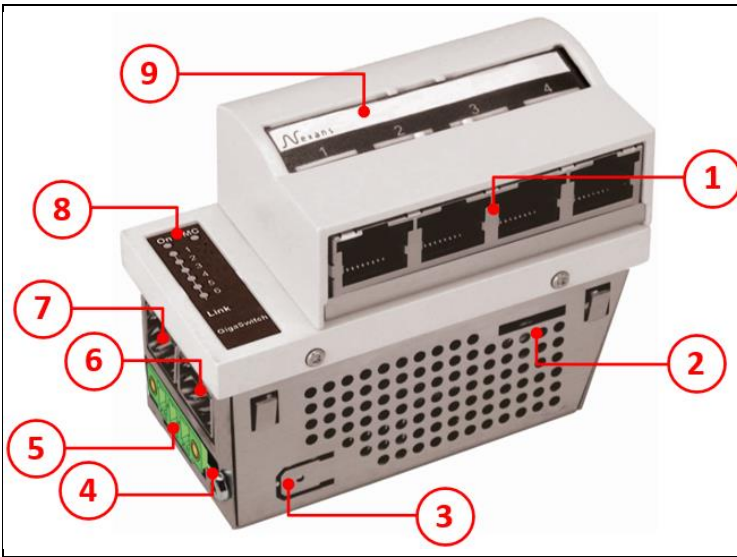

Number	Description
1	Port 1 - 4: RJ45 User Ports
2	Memory card slot (microSD)
3	Grounding terminal
4	Function input
5	3-pin AC power connection
6	Port 6: SFP Uplink
7	Port 5: SFP Uplink
8	Status LEDs
9	Labelling

88303975

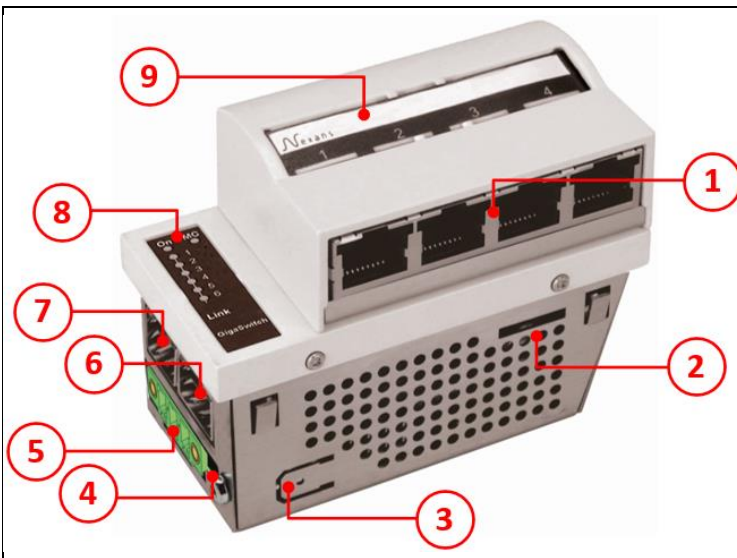

Number	Description
1	Port 1 - 4: RJ45 User Ports
2	Memory card slot (microSD)
3	Grounding terminal
4	Function input
5	3-pin AC power connection
6	Port 6: RJ45 Uplink
7	Port 5: SFP Uplink
8	Status LEDs
9	Labelling

PRODUCT LABELS

Nexans LANactive GigaSwitch devices are equipped with product labels for the purposes of quality assurance and documentation. The product labels contain unique device-specific information that can be used for project documentation. This information includes MAC address and serial number. The two numbers are unique and refer to each individual device.

The information about the respective MAC address is located twice on the switch. Once on the bottom side of the device and a second time below the labelling of the user ports. The sticker below the labelling can also be read when the GigaSwitch is installed.

Use the barcodes of the product label with the MAC address and serial number information to simply read in the device lists using commercially available scanners and document them in tabular form. Associate the MAC address with the information about the installation location and the switch description.

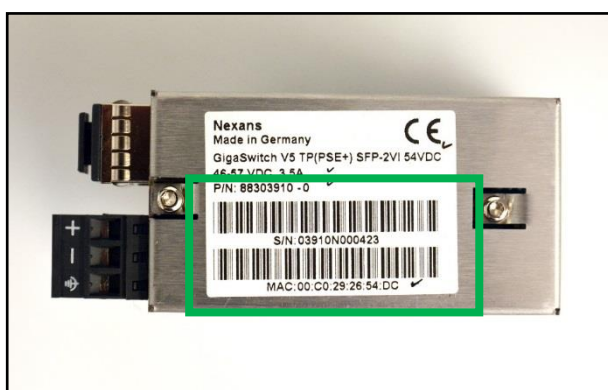

Figure 2: Product label

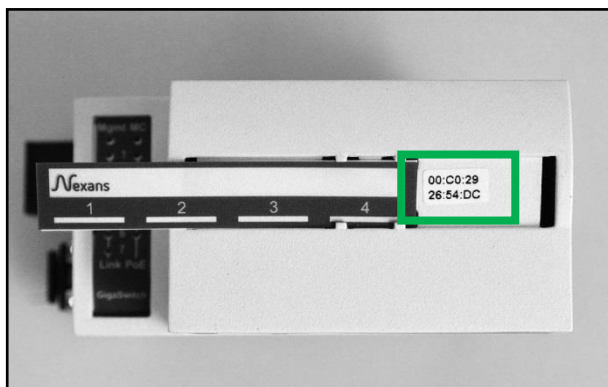

Figure 3: MAC-address label

SAFETY INSTRUCTIONS

Safety and warning instructions

Only qualified personnel may install and commission the device. Country-specific regulations must be observed.

- It is only allowed to use the provided 3-pin power connector.
- The dimensions of the supply lines must be sufficient for the connection scenario.
- After installation, cover the terminal area to prevent inadmissible touching of active parts.

MAINTENANCE AND REPAIR

The switches are maintenance-free devices. Repairs are only permitted by the manufacturer or by persons authorized by the manufacturer. In case of doubt, please contact the manufacturer.



CLEANING

The GigaSwitch can be cleaned using a cloth which has been dampened with a mild cleaning agent. Please take care that no cleaning agent enters the interior of the unit.

WASTE MANAGEMENT

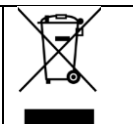
After use, the Nexans LANactive GigaSwitch and all electronic parts contained in the scope of delivery must be disposed of properly according to legal law at a responsible collection point.



	ATTENTION: Electrical damage For device protection, connect a thermomagnetic fuse.
	CAUTION: Danger due to electric shock! Never work with applied voltage.

Packaging

Do not throw away the packaging. The packaging has been designed for repeated use if not damaged during transport. Only the original packaging can reliably protect the unit from damage during later transport.

Checking for transport damage

Please check the unit for transport damage after unpacking. Transport damage can be assumed in particular if the packaging is visibly damaged. Do not try to operate an obviously damaged unit. This may result in further consequential damages.

Recovery after storage and transport

Humidity can condensate on the unit if the unit has been stored or transported at low temperatures and subsequently taken into a warm room. To avoid any damage please wait till any condensation has vanished from the unit's surface before starting the unit. The unit is operational only after it has reached the guaranteed operating temperature range (see Technical Data). The same applies also to prior storage at high temperatures.

INSTALLATION OF FTTO SWITCHES

Sophisticated design: The Nexans switches and Click-In power supplies support tool-free installation with a 45mm installation format. The compact design of the products makes it easy to integrate the devices into new and existing building installations. The integration of the network components can be adapted and executed according to individual needs.

Full flexibility: Nexans FTTO switches can be combined with a variety of standard installation materials from various international manufacturers. All FTTO switches can be easily used with the mounting frames, covers and profiles. Furthermore, Nexans offers its own universal mounting accessories to simplify the installation, assembly and disassembly of the devices and to ensure the best possible integration. Nexans also offers special and custom mounting kits.



Figure 4: Cable duct installation



Figure 5: Floor box installation



Figure 6: In-wall installation



Figure 7: On-wall installation



Figure 8: Desk installation



Figure 9: Communication pillar installation

HORIZONTAL AND VERTICAL INSTALLATION

Horizontal and vertical installation with a 45 mm Snap-in design

The GigaSwitches are designed primarily for installation in parapet and cable ducts with horizontal guidance. The low overall height and the vertical guidance of the connection lines extend the range of use also to underfloor systems, e.g. floor boxes. The switches feature a rotating switch head with Power over Ethernet function.

The head of the switch with RJ45 connectors can be mounted vertically or horizontally. There is therefore no need to stock separate system types.



Horizontal and Vertical Installation

Contact
Nexans LAN Systems
Tel.: +49 (0) 2166 27 2220
sales.ans@nexans.com

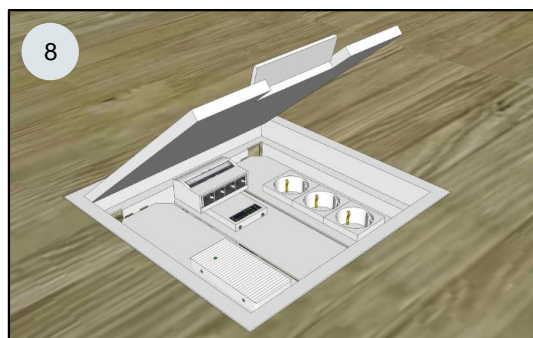
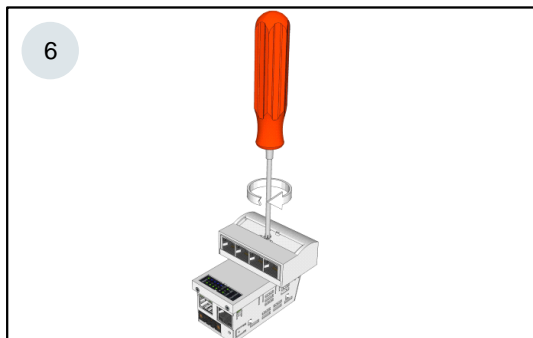
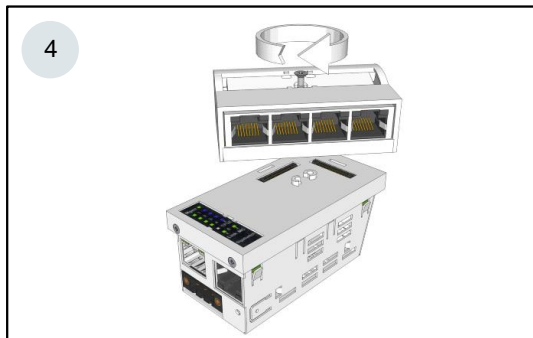
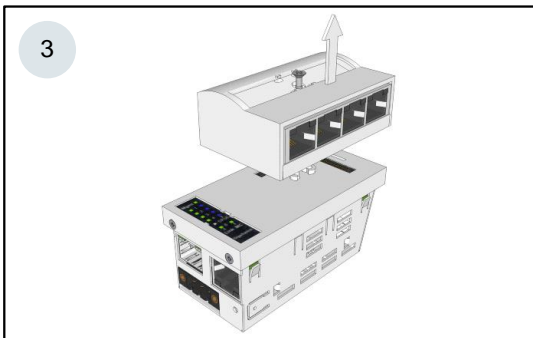
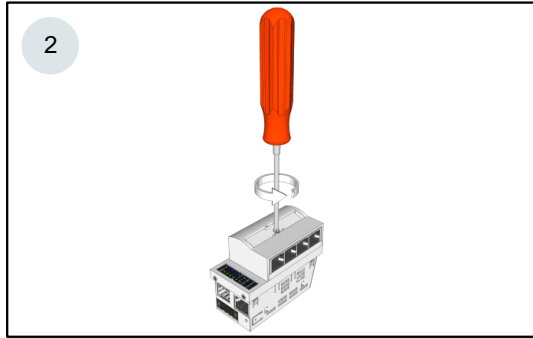

POWER CONNECTION

Pin assignment of the 3-pin DC connector

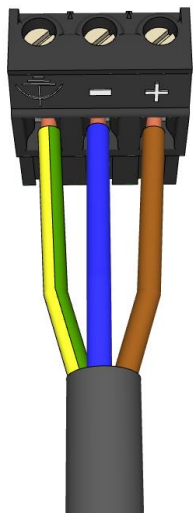

Figure 10: DC Pin assignment

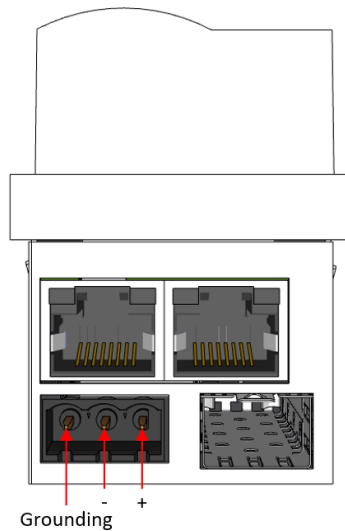

Figure 11: DC Power connection



In any case please check the correct pin assignment and the correct polarity of the wiring at the supply unit.

Input DC	Voltage typ. [V]	Diameter [mm ²]	Diameter[mm ²]	AWG	Length [mm]
FG / - / +	54V DC	0.75 - 2.5	0.75 - 2.5	19 - 12	8

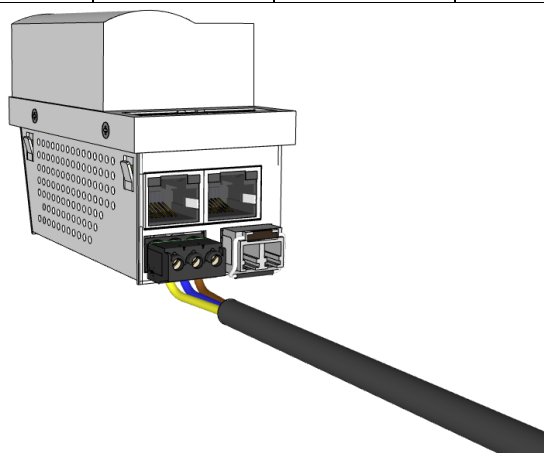

Figure 12: DC Power connection

Pin assignment of the 3-pin AC connector

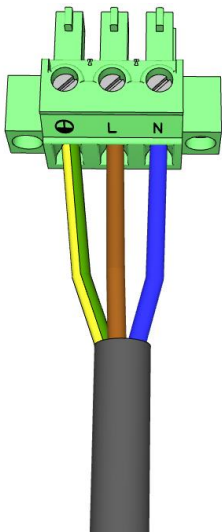

Figure 13: AC Pin assignment

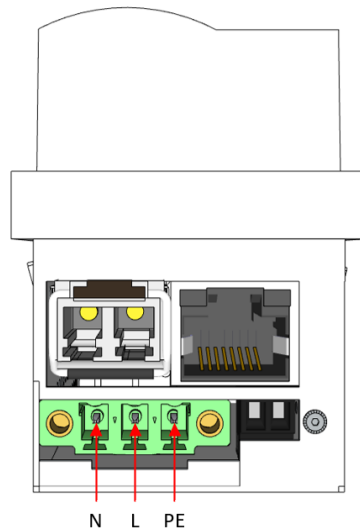
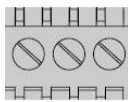

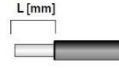



Figure 14: AC Power connection



In any case please check the correct pin assignment and the correct polarity of the wiring at the supply unit.

Input DC	Voltage typ. [V]	Diameter [mm ²]	Diameter[mm ²]	AWG	Length [mm]	Torque [Nm]
						
PE / L / N	230V AC	0.14 - 1.5	0.14 - 1.5	28 - 16	7	0.22 - 0.25

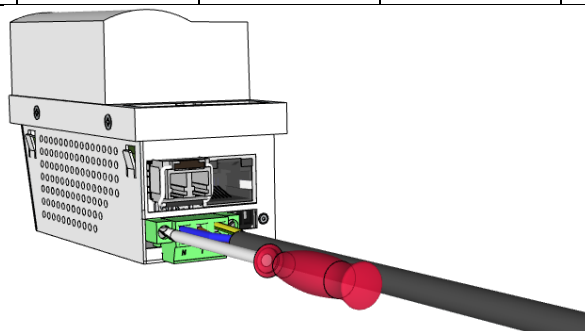

Figure 15: AC Power connection

GROUNDING

LANactive GigaSwitch with 54V DC connection

To prevent unwanted interference and failures, the correct grounding of the LANactive GigaSwitch is very important. This becomes much more important if Power over Ethernet (PoE) is used and multiple powered devices (PD) are connected to the GigaSwitch.

Nexans confirms that all LANactive switches are developed and manufactured according to the requirements of the PoE standards as defined by the Institute of Electrical and Electronics Engineers (IEEE) IEEE802.3af, IEEE802.3at and IEEE802.3bt.

In case of using a centralized power supply that powers multiple switches and thus multiple PoE devices, the grounding must be connected next to the central power supply. In this case the **plus** voltage must be grounded by connecting it to the potential equalization of the building. This is required because the positive voltage is permanently enabled by the GigaSwitch. The following figure shows the schematic of grounding the plus voltage.

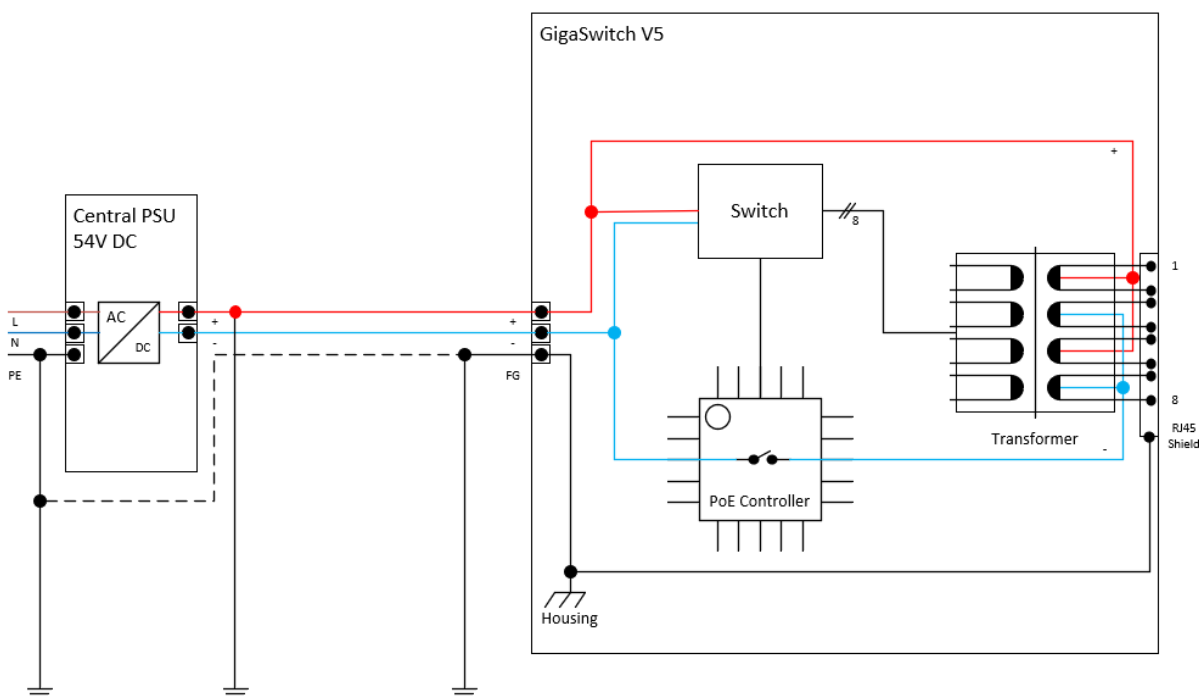

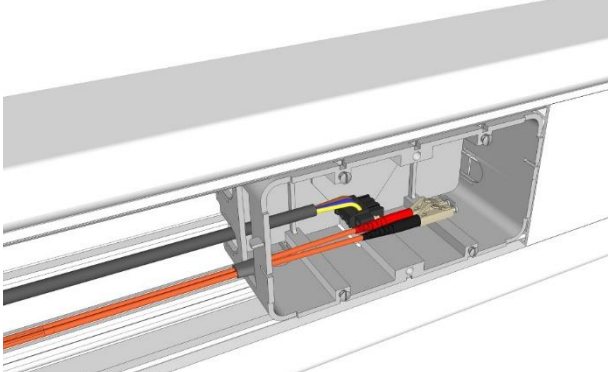
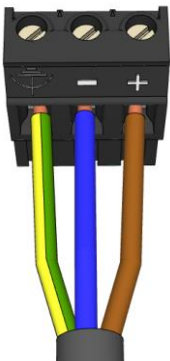

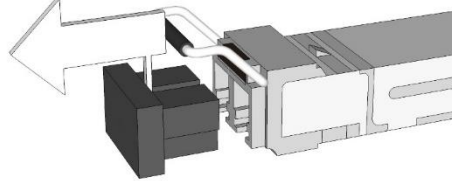

Figure 16: Block diagram of grounding



The switch can be grounded locally with the grounding terminal of the housing or connected to the central grounding by using a three-wired cable (+, -, Ground).



Never use the minus voltage for grounding! If minus is connected to ground and furthermore an end device has a wrong isolation, the risk of a short circuit is given. Especially some type of PCs and IP Cameras have an electrical connection between all four copper pairs of the RJ45 port and the ground instead of an isolation. As a result, the positive PoE voltage is connected to ground because the positive voltage is permanently enabled by the switch (see figure above). If the negative voltage is connected to ground at the central power supply and the positive voltage is connected to ground inside the end-device, the result is a short circuit between the negative and positive voltage of the central power supply via the common grounding of the building.

HARDWARE INSTALLATION

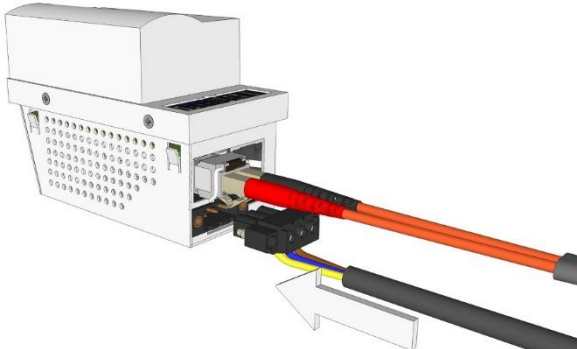
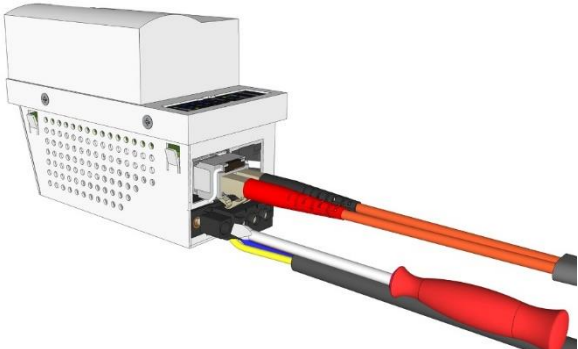
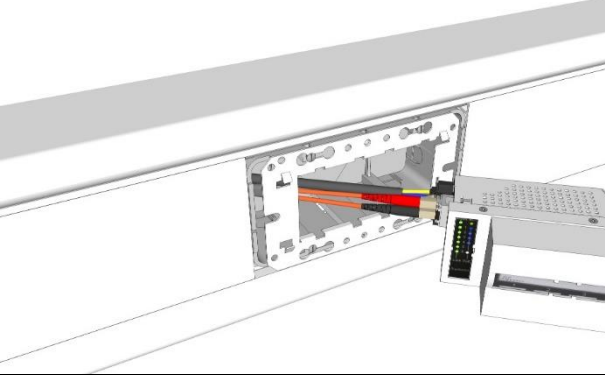
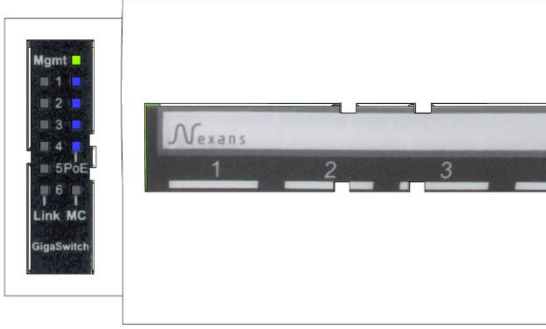
	
<p>1. Check the installation location. The cables should be loose and movable.</p>	<p>2. Note the assignment of the connector. The connection plug is included in the scope of delivery.</p>
	
<p>3. Remove the dust caps from the SFP slot. Plug the SFP module into the SFP slot and lock it.</p>	<p>4. Remove the dust caps from the SFP modules.</p>
	
<p>5. Connect the SFP module to the corresponding LC duplex fibre optic patch cable.</p>	<p>6. Use only the supplied microSD card. Insert the memory card into memory card slot of the switch.</p>

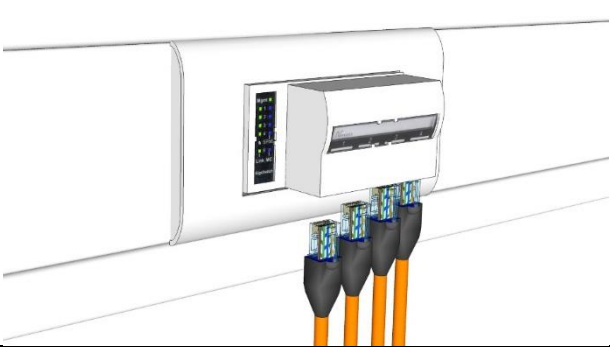
	
<p>7. Connect the 3-pin connector to the switch.</p>	<p>8. The green AC connector of the GigaSwitch is a screw-on type. Use a screwdriver to fix the connector to the switch.</p>
	
<p>9. Guide the switch with connected cables into the cable duct until the switch is engaged.</p>	<p>10. Switch on the power and check the power LED of the switch.</p>
	
<p>11. Check the Uplink LED, it lights up green and flashes if the switch has connectivity.</p>	<p>12. Connect the end-devices and check the corresponding LED for link and data.</p>

INSTALLATION DISTANCES

LANactive GigaSwitch and power supply are active devices that generate heat when they are running. In order to reduce the temperature of the components and surfaces, the distances between the individual installation locations must be respected. These distances depend on material and arrangement. Below are guidelines for minimum distance between both devices.

Distance	Description	Plastic cable ducts, mm	Metal cable ducts, mm
A	Distance between device beakers with GigaSwitch and Click-In power supply with 70W output power	150	100
A	Distance between device beakers with GigaSwitch and Click-In power supply with 130W output power	200	150

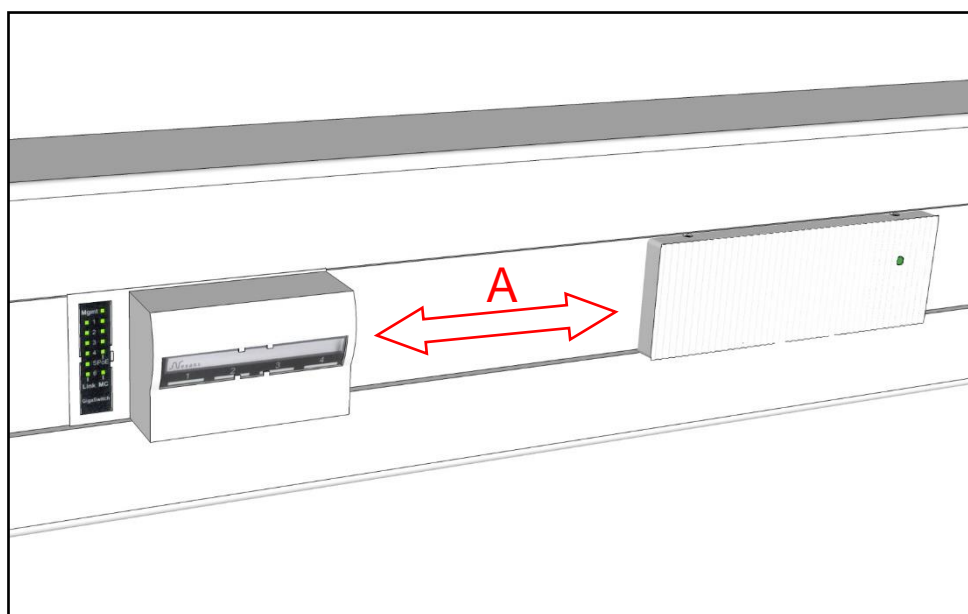
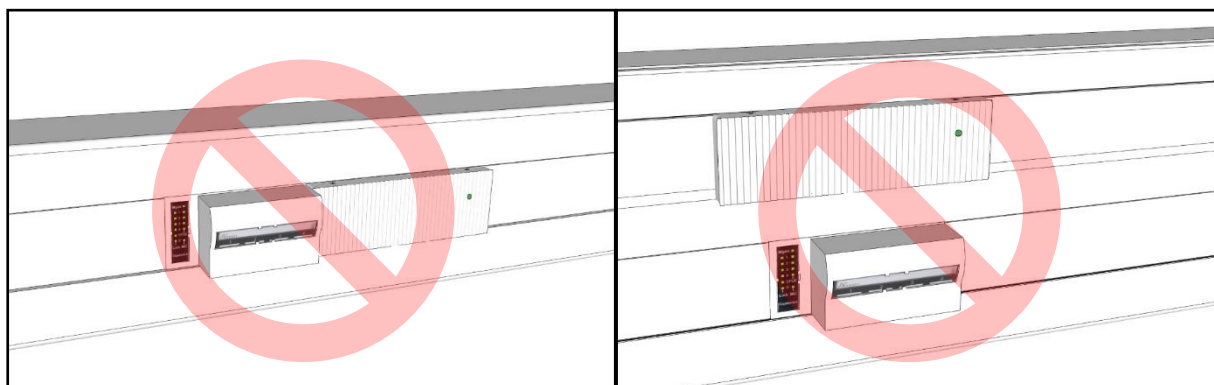

Figure 17: Installation distance

The installation of 2 active devices, switch and power supply, directly side by side is not allowed. This arrangement can lead to increased operating temperature, which causes a reduced life of the components.



POWER OVER ETHERNET

Power over Ethernet is an attractive and standardized alternative for the power supply of LAN equipment such as VoIP phones, Wireless LAN Access Points, IP video cameras etc., while using the "normal" Ethernet standard cable, i.e. without any additional cable tangle.

Function

An power sourcing equipment (PSE) ensures the power supply of a powered device (PD). Nexans LANactive GigaSwitch V5 series supports all two different PoE standards.

- PoE IEEE802.3af
- PoE+ IEEE802.3aft

For PoE and PoE+, the standard defines 3 modes of operation for power supply, which is ensured via different wire pairings of the TP data connection:

- Endpoint PSE mode A - power supply via TP pairs 1/2 and 3/6
- Endpoint PSE mode B - power supply via TP pairs 4/5 and 7/8
- Midspan PSE mode B - power supply through an external device via TP pairs 4/5 and 7/8

The PoE solution will only supply power if an appropriate powered device (PD) is detected. The following functions are checked prior to enabling PoE power supply:

- The active PSE source identifies the powered device (PD).
- The operational mode is detected.
- The required power class is detected based on the classification current.

Thus, any damages can be avoided, if the connected terminal unit is not standard-compliant.



In any case please check the correct pin assignment and the correct polarity of the PoE wiring at the terminal unit.

Mode A—Pairs 1/2 and 3/6

Power Source Equipment (PSE)		Powered Device (PD)	
MDI(X)		MDI	
1 BI_DB+	PoE-	PoE+	1 BI_DA+
2 BI_DB-	PoE-	PoE+	2 BI_DA-
3 BI_DA+	PoE+	PoE-	3 BI_DB+
4 BI_DD+			4 BI_DC+
5 BI_DD-			5 BI_DC-
6 BI_DA-	PoE+	PoE-	6 BI_DB-
7 BI_DC+			7 BI_DD+
8 BI_DC-			8 BI_DD-

Power Source Equipment (PSE+)

Thanks to the optional Power over Ethernet (PoE+) functionality, PoE-capable end devices can be supplied with power in accordance with IEEE 802.3at directly from the switch. The Power over Ethernet functions can be parameterized, controlled and monitored via management.

PoE class	Max. output power at PSE	Available power at PD	Classification signature	PoE standard
0	15.4 W	0.44 - 12.96 W	0 - 4 mA	IEEE 802.3af/at
1	4 W	0,44 - 3.84 W	9 - 12 mA	IEEE 802.3af/at
2	7 W	3.84 - 6.49 W	17 - 20 mA	IEEE 802.3af/at
3	15.4 W	6.49 - 12.95 W	26 - 30 mA	IEEE 802.3af/at
4	30 W	12.95 - 25.50 W	35 - 45 mA	IEEE 802.3at

Permitted voltage levels

The voltage ranges for the supply of switches are defined as follows:

PoE standard	Max. output power per port	Specified voltage range at the Power Source Equipment (PSE)	Voltage level at the switch, min. / typ. / max.
IEEE 802.3af (Type 1)	15.4W	44 - 57V DC	46 / 48 / 57V DC
IEEE 802.3at (Type 2)	30W	50 - 57V DC	50 / 54 / 57V DC

MEMORY CARDS AND CONSOLE CABLE

Memory cards for switches

Nexans memory cards are optional redundant encrypted storage (AES256) for FTTO switches which always stores its complete and most actual configuration and firmware automatically. The format of the memory cards is microSD.

To make network maintenance processes easier, Nexans memory cards have unique MAC address fixed on it. The GigaSwitch replaces its own MAC address with the one read from memory card. In case of a switch replacement the memory card can easily be moved from the failed switch to the new one. The MAC address, configuration and firmware will be taken on by the new GigaSwitch. In this case, no changes in the network policy or pre-setup works need to be done because the system will see the same switch as before.

Nexans Part No.	Description
88300691	microSD Card with MAC
88300693	microSD Card with MAC integrated

Console configuration cables

The V.24 console port on Nexans switches allows you to configure the switch on site and/or retrieve its status without an Ethernet network connection. Configuration via the V.24 console port provides the same functionality as configuration via Telnet or SSH. To connect via V.24 connection to the Nexans iGigaSwitch, Nexans offers a special cable. On the host side it has an USB connector and a proprietary 10-pin connector at the client side.

Nexans Part No.	Description
88300715	10-Pin to USB adapter for serial console



Figure 18: Nexans GigaSwitch console cable

LED BEHAVIOR

The Nexans LANactive GigaSwitch V5 has 15 different LEDs. In the following table the meaning of the differed LEDs and colours is listed.

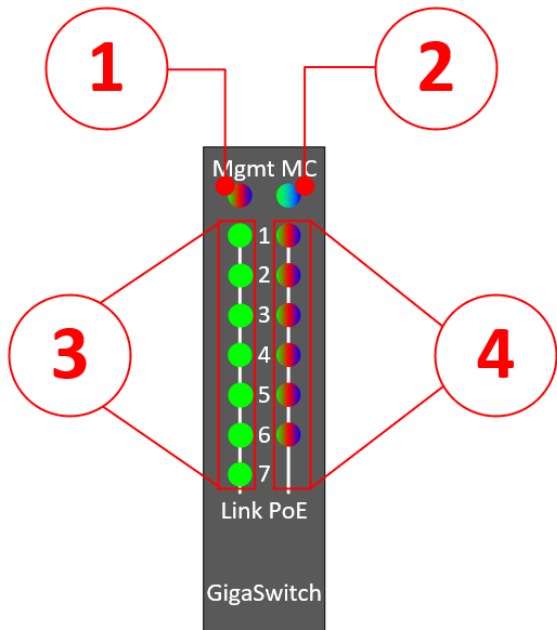

No.	LED colour	Description
1	Blue on	Switch is booting
	Green flashing	Switch is up, not yet received a valid IP address
	Green on	Switch is up and has a valid IP address
	Red on	Switch is up with fixed IP address
2	Off	No memory card detected
	Blue on	Switch is booting with configuration from memory card
	Green on	Switch is up, current flash configuration is mirrored to the memory card
3	Off	No link detected
	Green on	Link detected
	Green flashing	Data traffic detected
4	Off	PoE disabled
	Blue on	PoE enabled
	Green on	Powered Device detected
	Red on	PoE voltage has been switched off due to an error

Figure 19: GigaSwitch LEDs

START-UP – BOOTING

Booting with Factory Default Settings

By default, the switch loads all configuration parameters stored in the flash during the boot process.

In case the customer has ordered a default customized configuration, this configuration is written into the flash during production process and is available for the very first start-up.

Nexans default configuration comes with DHCP for addressing the switch. The switch sends a DHCP request as soon as the Management LED is permanently on. If it receives a valid response from a DHCP server, the IP parameters are accepted, and the management module can be immediately accessed via the assigned IP address. If the switch does not get a response, the DHCP request is repeated at increasing time intervals (with a maximum interval of approx. 30 seconds).

If the switch is booted with a plugged-in MC card having a valid switch configuration, the 'MC' LED will light up in blue for some seconds during booting. When the loading of the configuration of the MC card is completed, the 'MC' LED is permanently green.

Zero-Touch Configuration

In combination with Nexans LANactive Manager (Controller version), all Nexans GigaSwitch V5 systems support Zero Touch Configuration (ZTC). With ZTC the configuration process and the programming of firmware upgrades can be fully automated. If ZTC is enabled, new switch configurations and firmware will automatically be provided by the Zero Touch Configuration Controller (subsequently referred as LANactive Manager). The LANactive Manager is a separate server system or a virtual server on a dedicated computer in the network.

Zero Touch Configuration is enabled by default, if the admin account is set to factory default (name: "admin", password: "nexans").

On start-up the GigaSwitch checks whether Zero Touch Configuration is enabled. If this is the case, the switch registers at the Controller to get new configurations or firmware. For this purpose, the switch must know the IP address of the Controller that the switch can retrieve in three different ways:

1. via Nexans-specific DHCP option 43 (if DHCP is enabled)
2. via DNS server using DHCP options 6 and 15 (if DHCP is enabled)
3. via static Controller IP address configured in the switch

The IP address of the Controller can be an IPv4 address or IPv6 address.

Note: If option 2 is used, the DNS server must be configured with the IP address, the name of the LANactive Manager, and the domain. The LANactive Manager name must be set to "**nexans-controller**".

CONFIGURATION- AND RESET BUTTON

The pushbuttons are accessible after removing the LED cover plate. They can be operated using a thin pin, such as a bent-open paper clip.

IMPORTANT NOTE:

The boot functions '*Booting with fixed IP address*' and '*Booting with factory default settings*' can be individually disabled via the management in order to prevent an accidental or deliberate manipulation by the user. However, after disabling these options, a reset of the switch to factory default settings is only possible via management access. If no access is possible via the management feature, e.g. because name or password are unknown or the VLANs are configured wrongly, the switch can nevertheless be reset via a special reset plug.

Nexans Part-Nr.	Description
88301208	Reset-Adapter for Switch Management

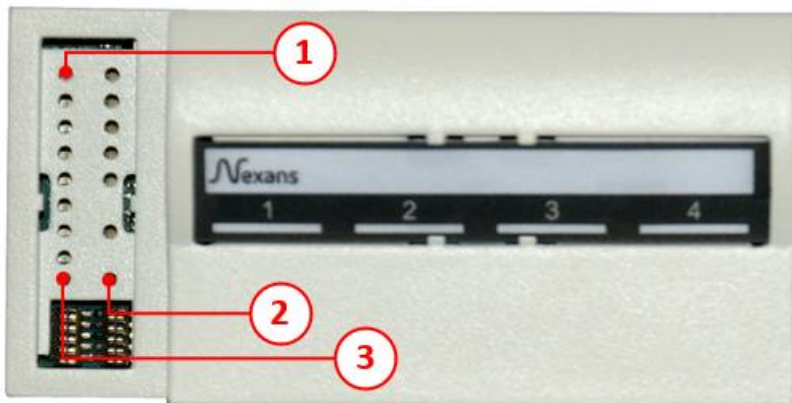

- 1 Management LED
- 2 Reset Pushbutton
- 3 Configuration Pushbutton

Figure 20: Mgmt. LED and Cfg/Reset Pushbutton

Configuration pushbutton

1. Hold configuration pushbutton >3 sec.

By pressing and holding the configuration pushbutton (min. 3 seconds) the switch will change into the configuration mode, which is indicated by the Management LED switching off. As soon as the Management LED is permanently off, the pushbutton must be released. A rapidly flashing blue Management LED shows that function number 1 has been selected.

2. Briefly pressing configuration pushbutton

By briefly pressing the configuration pushbutton (min. 0.1 second) the desired function can be selected, which is indicated via the respective LED colour:

1	●	Lights blue	Booting with flash configuration
2	●	Lights red	Booting with fixed IP address (172.23.44.111)
3	○	Lights white	Booting with factory default settings
4	●	Lights cyan	Booting with customer default settings
5	●	Lights magenta	Booting without customer default settings

3. Hold configuration pushbutton >3 sec.

In order to execute the selected function, the pushbutton must be pressed and held for at least 3 seconds. The Management LED flashes briefly and switches off to show that the switch has accepted the command. Now the pushbutton can be released and the switch will boot in selected mode.

Note: The configuration mode stops automatically, if the pushbutton is not pressed for more than 30 seconds.

Note: The functions four and five are only displayed if the respective configuration is stored.

Reset pushbutton

By pressing the Reset- and Configuration-Button simultaneously a hardware reset of the switch is executed.

Note: A hardware reset is equivalent to a short interruption of power supply.

LANACTIVE MANAGER

Nexans LANActive Manager is a centralized software solution that provides an easy and comfortable way of configuration, management and supervision of all Nexans Ethernet switches.

Note: LANActive Manager is optionally, all Nexans LANActive switches can also be managed locally.

LANActive Manager can be installed as stand-alone version and used as a desktop application for single or multiple users. This installation is perfect for on-site network engineers who are connected locally.

The LANActive Manager with Controller License is a client-server software architecture that is optimized for huge FTTO network installations. It allows simultaneous access from different clients via web interface and supports the fully automated configuration process Zero-Touch Configuration.

Nexans Part. No.	Description
88301908	LANActive Manager Single User Licence
88301909	LANActive Manager Company Licence
88301920	LANActive Manager Controller Licence

Zero-Touch Configuration

Nexans LANActive Zero-Touch Configuration is a contemporary way of designing, building and operating networks with minimum effort. The use of LANActive GigaSwitches together with the LANActive Manager ensures that networks are flexible and scalable. After connecting a Nexans LANActive GigaSwitch to a network segment, the switch will automatically link to its controller to receive provisioned firmware and configuration.

LANActive Manager with Controller License

Next to Zero-Touch Configuration the LANActive Manager with Controller License is used as a central logging and alarming instance for the network. It collects status information as well as errors from the FTTO switches and can forward dedicated information via Email.

Additional features supporting daily business and debugging functions are optimized based on customer demands.

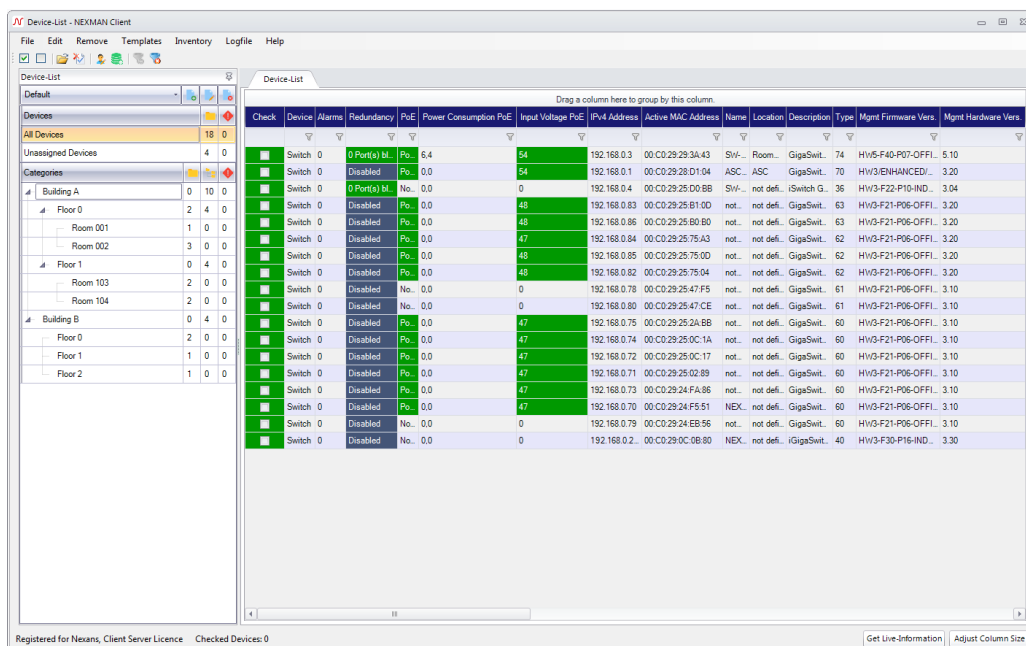

Figure 21: LANActive Manager

GIGASWITCH PRODUCT LIST

54V DC FTTO switches

GigaSwitch V5 TP(PSE+) SFP-2VI 54VDC

Nexans article number: 88303910



GigaSwitch V5 TP(PSE+) SFP-2VI; 44 - 57V DC; WxHxD [mm]: 93 x 45 x 69 (35); Toolless/Click-in; User Ports: 4x 10/100/1000; Uplink: 1x 10/100/1000 TP (PSE+), 2x 100/1000 SFP; PoE: 5x 30W IEEE 802.3at (150W); WEB/Telnet/SSHv2/SNMP/LANactive Manager, Security, RSTP/MSTP, SCP, QoS, VLANs

GigaSwitch V5 TP SFP-2VI 54VDC

Nexans article number: 88303920



GigaSwitch V5 TP SFP-2VI; 44 - 57V DC; WxHxD [mm]: 93 x 45 x 69 (35); Toolless/Click-in; User Ports: 4x 10/100/1000; Uplink: 1x 10/100/1000 TP, 2x 100/1000 SFP; PoE: 4x 30W IEEE 802.3at (150W); WEB/Telnet/SSHv2/SNMP/ LANactive Manager, Security, RSTP/MSTP, SCP, QoS, VLANs

GigaSwitch V5 2TP(PSE+) SFP-VI 54VDC

Nexans article number: 88303990



GigaSwitch V5 2TP(PSE+) SFP-VI; 44 - 57V DC; WxHxD [mm]: 96 x 45 x 69 (35); Toolless/Click-in; User Ports: 4x 10/100/1000; Uplink: 2x 10/100/1000 TP (PSE), 1x 100/1000 SFP; PoE: 6x 30W IEEE 802.3at (150W); WEB/Telnet/SSHv2/SNMP/ LANactive Manager, Security, RSTP/MSTP, SCP, QoS, VLANs

GigaSwitch V5 2TP(PD-F+) SFP-VI 54VDC

Nexans article number: 88303991



GigaSwitch V5 2TP(PD-F+) SFP-VI; 44 - 57V DC Powered Device; WxHxD [mm]: 96 x 45 x 69 (35); Toolless/Click-in; User Ports: 4x 10/100/1000; Uplink: 1x 10/100/1000 TP (PD), Uplink: 1x 10/100/1000 TP (PSE), 1x 100/1000 SFP; PoE: 5x 30W IEEE 802.3at (150W), PD Forwarding; WEB/Telnet/SSHv2/SNMP/ LANactive Manager, Security, RSTP/MSTP, SCP, QoS, VLANs

GigaSwitch V5 2TP SFP-VI 54VDC

Nexans article number: 88303992



GigaSwitch V5 2TP SFP-VI; 44 - 57V DC; WxHxD [mm]: 96 x 45 x 69 (35); Toolless/Click-in; User Ports: 4x 10/100/1000; Uplink: 2x 10/100/1000 TP, 1x 100/1000 SFP; PoE: 4x 30W IEEE 802.3at (120W); WEB/Telnet/SSHv2/SNMP/ LANactive Manager, Security, RSTP/MSTP, SCP, QoS, VLANs

230V AC FTTO switches

GigaSwitch V5 SFP-2VI 230VAC

Nexans article number: 88303971



GigaSwitch V5 SFP-2VI; 110 - 240V AC; WxHxD [mm]: 95 x 45 x 69 (35); Toolless/Click-in; User Ports: 4x 10/100/1000; Uplink: 2x 100/1000 SFP; PoE: no support; WEB/Telnet/SSHv2/SNMP/ LANactive Manager, Security, RSTP/MSTP, SCP, QoS, VLANs

GigaSwitch V5 TP SFP-VI 230VAC

Nexans article number: 88303975



GigaSwitch V5 TP SFP-VI; 110 - 240V AC; WxHxD [mm]: 94 x 45 x 69 (35); Toolless/Click-in; User Ports: 4x 10/100/1000; Uplink: 1x 10/100/1000 TP, 1x 100/1000 SFP; PoE: no support; WEB/Telnet/SSHv2/SNMP/ LANactive Manager, Security, RSTP/MSTP, SCP, QoS, VLANs

ACCESSORIES



Memory Cards

Nexans Part No.	Description
88300691	microSD Card with MAC
88300693	microSD Card with MAC integrated

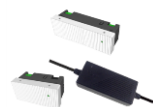

Nexans FTTO Power Supplies

Nexans Part No.	Description
88646210	Click-In Power Supply 54VDC/70W 90x45
88646241	Click-In Power Supply 54VDC/130W 135x45
88646066	Installation Power Supply 54VDC/65W
88646077	Power Supply for Desk Devices 54VDC/65W



Small Form Factor Pluggable Transceiver

Nexans Part No.	Description
88646015	Nexans SFP 1000 Transceiver GI(LC)E; Gigabit Ethernet; Multimode; TX/RX: 850/850; 550 m; LC-duplex; DDM Support; temp.r: -20°C/+85°C; dual fibre; Budget: 9 dB
88646016	Nexans SFP 1000 Transceiver SM(LC)E L10; Gigabit Ethernet; Singlemode; TX/RX: 1310/1310; 10 km; LC-duplex; DDM Support; temp.r: -40°C/+85°C; dual fibre; Budget: 12 dB
88646073	Nexans SFP 1000 Transceiver SF3(LC)E L10; Gigabit Ethernet / Single fiber BiDi Modules; Singlemode; TX/RX: 1310/1550; 10 km; LC-simplex; DDM Support; temp.r: -40°C/+85°C; single fibre; Budget: 12 dB
88646075	Nexans SFP 1000 Transceiver SF5(LC)E L10; Gigabit Ethernet / Single fiber BiDi Modules; Singlemode; TX/RX: 1550/1310; 10 km; LC-simplex; DDM Support; temp.r: -40°C/+85°C; single fibre; Budget: 12 dB

Support Nexans Support-Packages

Nexans Part No.	Description
88642010	Support-Package "Engage" - Third Level Support
88642011	Support-Package "Getting Started" - Third Level Support
88643001	Enhanced Network Management Training

OFFICES

Advanced Networking Solutions

Bonnenbroicher Str. 2-14
41238 Monchengladbach
Germany
Tel: +49 2166 27-2220
Fax: +49 2166 27-2499

Nexans Cabling Solutions

Alsebergsesteenweg 2, b3
B-1501 Buizingen
Belgium
Tel: +32 (0)2 363 38 00
Fax: +32 (0)2 365 09 99